

# IAV Control System Concept for Gaseous Fuel Drives

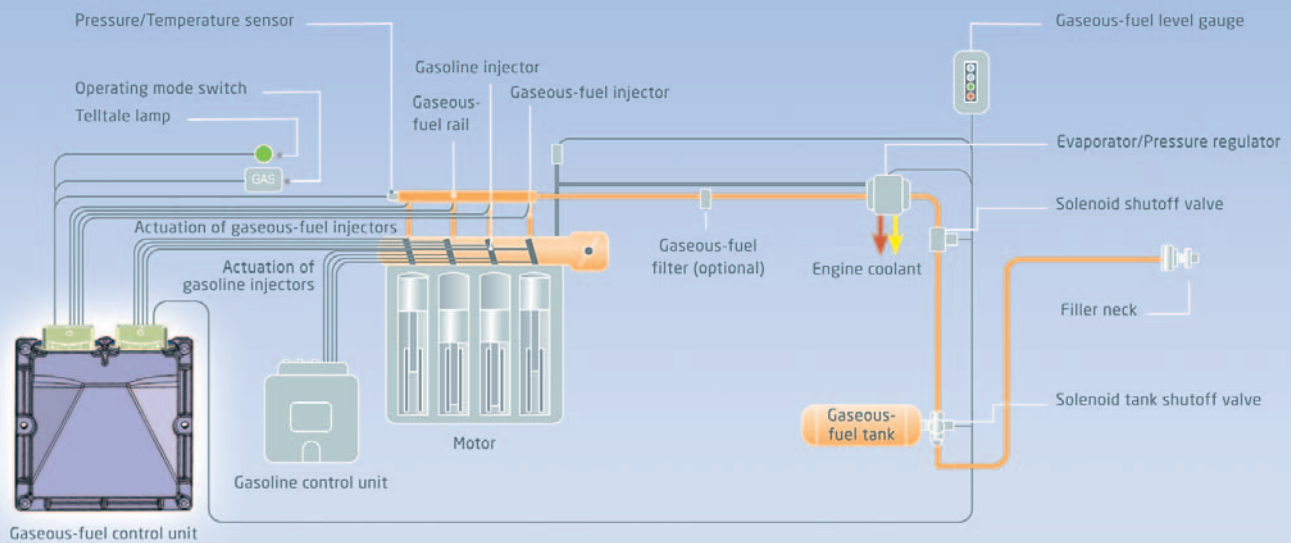

Diagram of IAV's gaseous-fuel master-slave system

09/2008

As conventional fuels like gasoline and diesel become more expensive across the globe, there is a growing demand to develop alternative drive systems for various markets. As short-term solutions, LPG and CNG powertrain systems are attracting increasing attention.

IAV GmbH Ingenieurgesellschaft Auto und Verkehr (IAV) is one of the world's leading engineering providers to the automotive industry. The company has been dedicated since 1990 to developing production-ready solutions for CNG and LPG systems as well as to small-volume conversions using 0-mileage aftermarket concepts. As a Qualified Vehicle Modifier (QVM), IAV has comprehensive, precision knowledge in all areas of automotive development, providing the expertise that is necessary for perfectly integrating gaseous fuel systems while taking full account of the interfaces and influencing factors that are involved. Based on our many years of experience, we have consistently and continuously improved the quality, safety, efficiency and reliability of gaseous fuel drives. This makes IAV one of today's leading, recommended and award-winning providers in this sector.

A newly developed slave control unit for gaseous fuel systems provides a fast and cost-effective means of converting almost all existing gasoline concepts into a bivalent gasoline and gaseous-fuel system without changes to the existing gasoline master controller. The master-slave concept combines the use of validated gasoline system data with the added flexibility of a slave controller and an optimized, OEM-specific component set for gaseous fuel systems (capable of being combined with various gas injectors, sensors, and actuators).

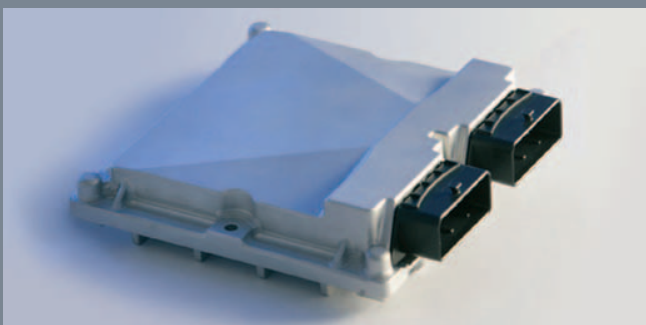

## Advantages of the New Gaseous-Fuel Slave Controller

*The slave controller for gaseous-fuel systems meets world market requirements and has been developed in compliance with German and international standards.*

- ▶ This guarantees perfected functionalities and appropriately validated systems for mass production

**Open System Interfaces** - The control unit hardware can be combined with a variety of EMS components and systems.

- ▶ As a result, components can be selected that are ideally suited to each system in terms of function and/or cost

**Easily adaptable to new functions** - Fully automated code generation for mass production and OEM calibration standards ensure rapid adaptation to new functionalities and short times to market.

- ▶ Specific requirements can be realized short-term in high quality. This optimizes system costs and permits fast response to changing market requirements

**Flexibly scalable hardware** - Hardware design tailored to four and six-cylinder engines and all vehicle-related requirements.

- ▶ Hardware configuration can be optimized to meet a wide range of hardware requirements while leaving software structures unchanged

**Demand-based system integration support** - We can offer everything from the one-off project to turn-key solutions:

- ▶ Tailored overall concept
- ▶ Calibration and validation
- ▶ Component assessment
- ▶ System development and integration
- ▶ Homologation
- ▶ Modifications to the electrical system

**Compatible calibration tools** - Calibration through INCA PC interface

- ▶ Existing development environments can be used for gaseous-fuel systems while at the same time applying proven processes.

**Made in Germany** - Control unit hardware is produced in Germany.

- ▶ High quality of production and validation guarantee lasting service

**Outstanding value for money** - Optimized solutions that

- ▶ Save time
- ▶ Ease the strain on capacities and resources
- ▶ Cut cost



Gaseous-fuel instrumentation in OEM quality



Packaging of underfloor LPG tanks

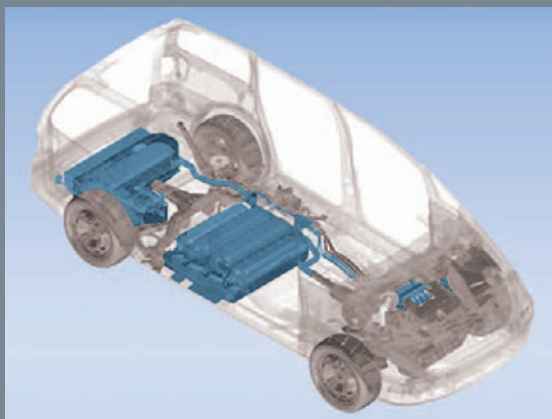

Integrated vehicle concepts for mass production

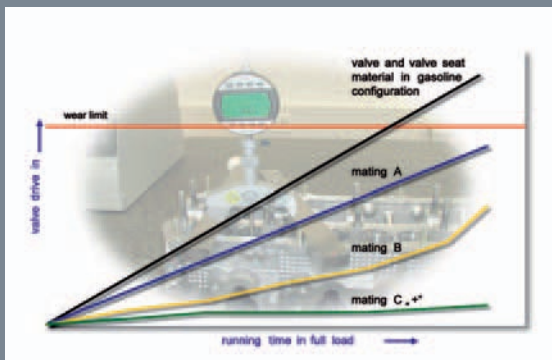

Development to reduce valve wear in gaseous-fuel mode

Gas Propulsion Department  
 +49 30 39978-9624 or -9623  
 System Design Department  
 +49 5371 805-2742  
 gassystems@iav.de  
 www.iav.com

## IAV Expertise in Gaseous-Fuel Vehicles

### Development to SOP level

IAV has proven its expertise in developing gaseous-fuel vehicles to SOP level in a variety of projects. Alongside turn-key solutions for production-ready CNG and LPG development projects, these activities also include constructing prototypes and realizing demonstrator vehicles. Advance development topics, such as combustion-process and base-engine development services (particularly on the valvetrain side), are areas in which IAV can draw on a wealth of experience. As such, IAV benefits from a comprehensive understanding of the way in which all products interact, knows their strengths and weaknesses and can provide the best possible solutions to avoid recall situations.

### Examples of Production-Ready Development Projects:

- ▶ Turn-key development of a production vehicle with bivalent CNG drive (single-controller concept from 2002)
- ▶ Development of the world's first production vehicle with liquid LPG injection (single-controller concept from 2004)

### QVM (Qualified Vehicle Modifier) Conversion

With over 6,000 CNG and LPG conversions (as of 2008), IAV is Germany's No.1 vehicle modifier. Across the globe, there are over 80,000 vehicles running on IAV's gaseous-fuel systems.

### Quality and Reliability

- ▶ Continuously advanced systems and components
- ▶ Optimum integration based on comprehensive base-vehicle expertise (Qualified Vehicle Modifier)
- ▶ Existing gasoline-fuel system left entirely unchanged (bivalent drive concept)

### Safety

- ▶ Well documented through crash tests
- ▶ Certification of all gaseous fuel system components under ECE-R67.01 and ECE-R 110 (-40 °C), can be registered throughout Europe
- ▶ Gaseous fuel system is registered in Germany under ECE-R 115
- ▶ Constant monitoring of all emission-relevant gas components by the engine management system in both operating modes

### Service

- ▶ Preparation of complete workshop service manuals
- ▶ Competent support and service
- ▶ Training of workshop personnel by experts (over 220 service points in Germany alone)
- ▶ GSP/GAP training

Made in Germany -  
 produced exclusively by  
 MGH Germany GmbH, Berlin

