

Developing Distributed Functions

From the E/E Architecture Concept to the Volume Product

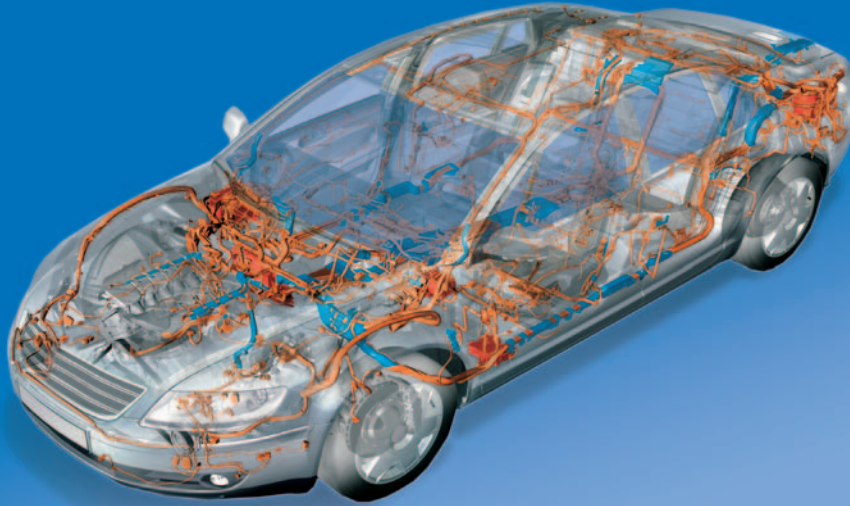

Distributed systems define today's and tomorrow's vehicle architectures

We support automobile manufacturers and component suppliers in realizing distributed systems in the motor vehicle from the concept phase to the volume product.

Our many years of experience in developing automotive electrics/electronics make us a competent and reliable partner. Covering all aspects of developing distributed systems - from the architecture concept to the documentation of distributed systems - our engineering services combine experience in mass-production development and a practical focus with method and tool-related expertise in applying innovative approaches to function-oriented E/E development while never losing sight of what is achievable.

Employing over 3,000 staff members worldwide, IAV is one of the leading engineering providers to the automotive industry. Our core competencies are in providing perfected, production-ready solutions in all areas of powertrain, electronics and vehicle development. As an innovative company, we have our own advance development specialists, carry out future-oriented primary research work and follow an interdisciplinary approach. Our clients include all major automobile manufacturers and component suppliers.

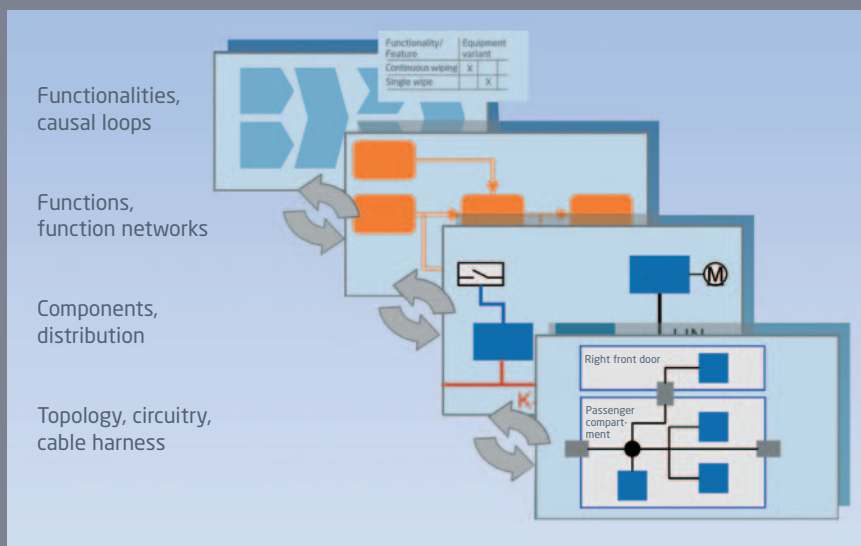

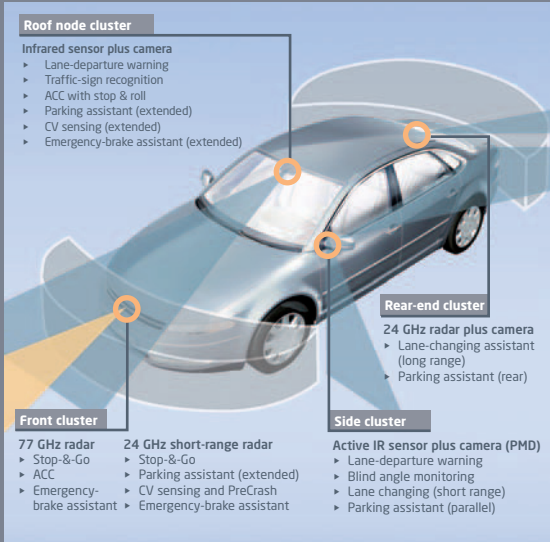

Complex E/E functions

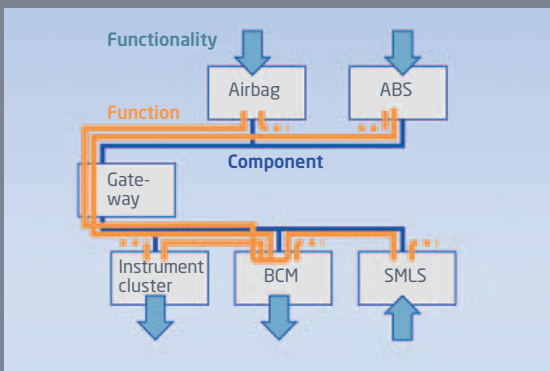

Distributed functions in the component network

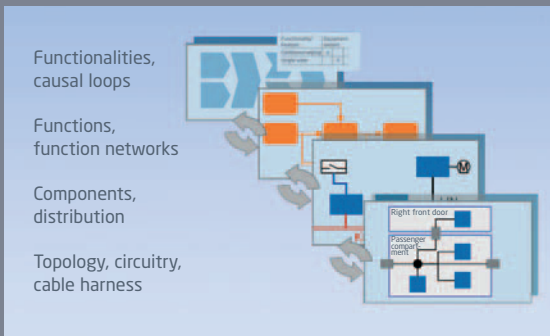

Layer concept for model-based architecture design

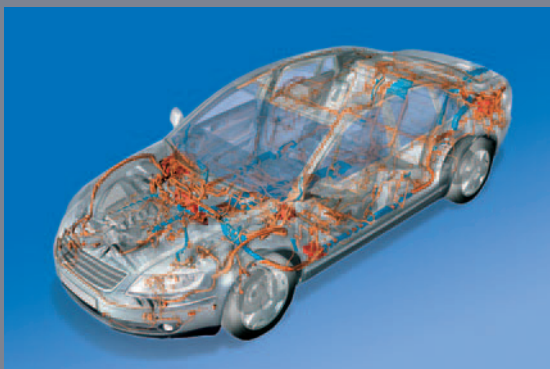

Electrical system concept

The growing number of electrically/electronically realized functions as well as the cross-functional use of sensors, computing infrastructure, controls and indicators is producing a steep rise in the degree to which electrical/electronic systems are distributed in the vehicle. At the same time, it is necessary to realize, test and apply highly distributed functions in other vehicle projects at low cost. This produces the necessity to realize E/E functions on both a distributed and modular basis and to integrate them in scalable E/E architectures. This is where IAV provides engineering services in the following focal areas:

Concepts and Development of Distributed E/E Functions

Designing distributed E/E functions demands a perspective that encompasses the domains of powertrain/chassis/comfort/info-tainment, extends beyond the horizon of electrics/electronics and considers the whole vehicle. This is why it is often necessary to involve several specialized departments in calibrating, planning and cross-coordinating distributed functions. We design distributed E/E functions and, working with you, take them to SOP level. Doing so, we draw on our many years of experience in the fields of E/E function development, networking, vehicle electrical system, overall vehicle and E/E integration testing.

E/E Architecture Concept Formulation and Assessment

We support you in formulating and assessing E/E architecture concepts and accompany their realization to the point of mass production. Geared to your requirements, we use modern methods and tools for modeling E/E architectures that provide the capability of modeling, documenting, checking consistency and assessing architectures in relation to aspects such as weight, energy demand, costs, package, variety, modularization and re-utilization. Beyond this, we prototype network concepts with a view to visualizing and validating them in practice. This is where we combine our knowledge of modern, model-based architecture design methods and tools with pragmatism, practical relevance and experience in mass-production development.

System Description of Distributed E/E Functions

During the mass-production development process, work is extensively divided among the various specialized activities involved, with distributed functions being realized on a component-focused basis and in many cases spread across several organizational units. We have many years of experience and are practiced in collating, editing and presenting information in an effective way from across the company. Using system descriptions brought together in a single, compact document, we provide everyone involved with a comprehensive picture of the structure and working principle of distributed functions. Developers, integrators and testers all benefit from the documentation compiled and updated during the course of a project. The system description provides a basis for developing E/E architectures in subsequent projects.

Every project benefits from our wealth of skills and expertise in the overall vehicle. We can provide you with support from the concept phase to mass production, combining innovative strength with pragmatism and experience in the production development business.