

Fully Variable Mechanical Valve Control

For Continuous Variation of Opening Periods and Valve Lift

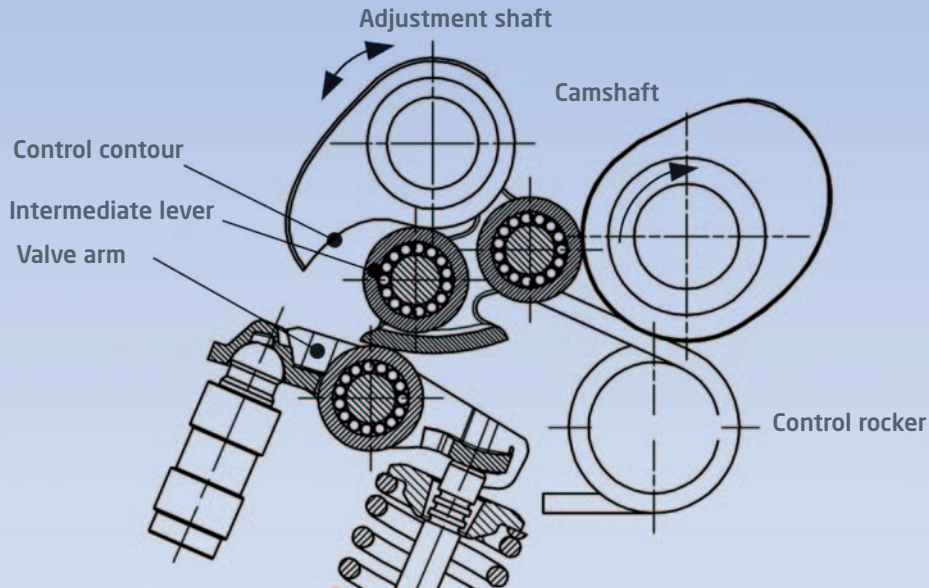

Why Fully Variable Mechanical Valve Control?

- ▶ Huge gas exchange potential at part and full load
- ▶ Robust and easy to control
- ▶ Good system energy balance with reduced operating energy input as a result of valve lift control in part-load range
- ▶ Use of conventional technologies for treatment, assembly, maintenance, development and testing
- ▶ Relatively minor alterations to engine set-up and vehicle (e.g. 14V on-board electrical system retained)
- ▶ Proven suitability of fully variable mechanical valve trains for mass-production

Variable Mechanical Valve Control for increasing the efficiency of internal combustion engines:

- ▶ Reduced gas exchange losses
- ▶ Reduced mechanical operating energy input at part load
- ▶ Increased charging efficiency

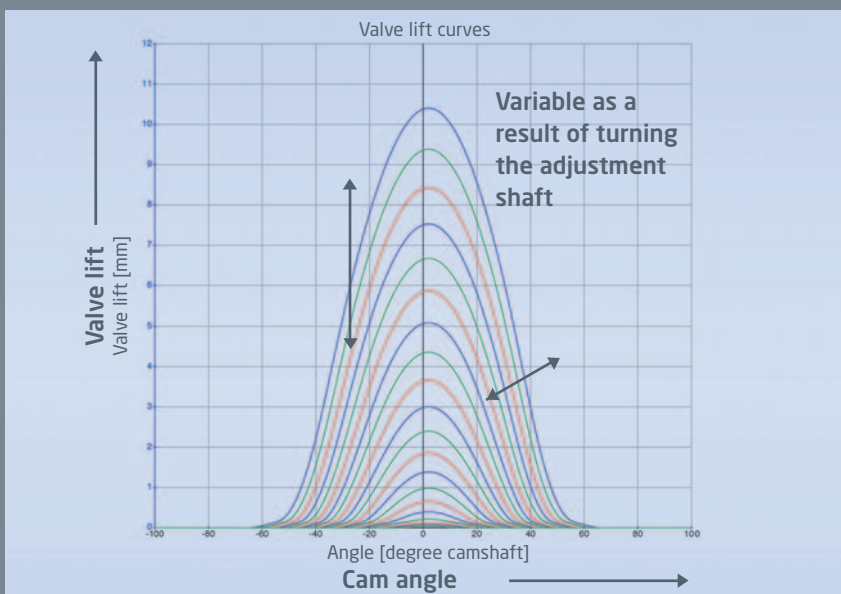

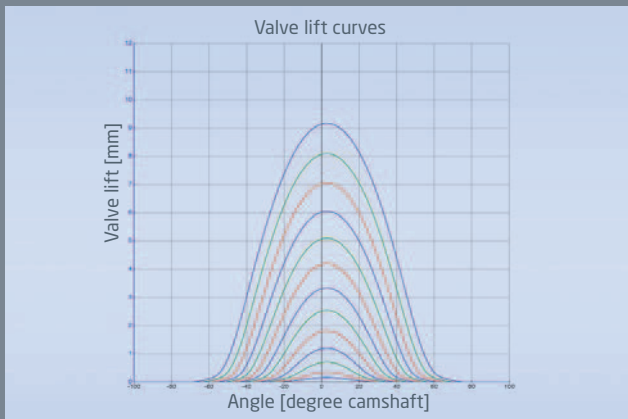

Valve lift

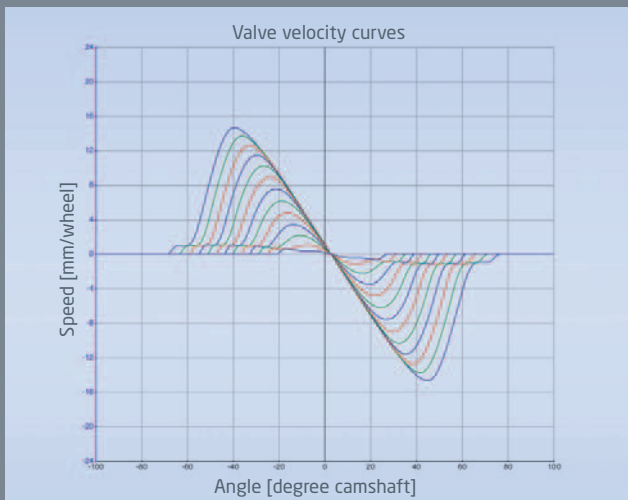

Valve speed

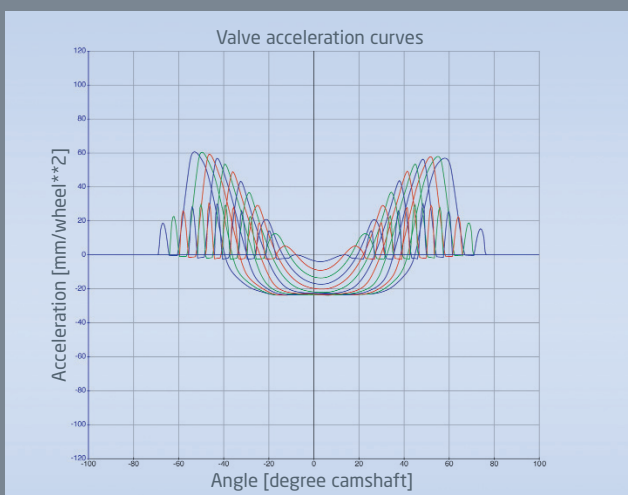

Valve acceleration

The operating principle

- ▶ Movement of intermediate lever along a stationary control contour
- ▶ Driven by cam-like cam disk
- ▶ Valve lift and valve opening period changed by turning the control contour
- ▶ Zero lift at maximum angle of adjustment

Valve Lift in Relation to Position of Adjustment Shaft

As a result of the cam-related deflection of the control rocker, the intermediate lever moves along the base circle of the control contour until making contact with it. In line with the control contour configuration, the intermediate lever is then moved in the direction of the valve lever, and valve lift starts. The lifting movement continues as a result of the combined effects of the cam contour and control contour until maximum lift is achieved at the cam. By turning the control shaft, it is possible to alter the opening time, lift of the valve and lifting dynamics.

Zero Lift Movement

If the system is set for zero valve lift, the intermediate lever moves along the base circle of the control contour. Drive is determined by the cam moving the control rocker. As the intermediate lever is not brought into contact with the control contour, there is no deflection in the direction of the valve lever. A return spring is necessary to keep the cam follower in contact with the cam throughout, with the ideal position of the return spring being on the control rocker. Depending on the package available, the position can be chosen to suit constructional requirements.

Scope of Services in the Area of Valve Control

- ▶ Design and layout
- ▶ Calculation of complex valve kinematics and variable transmissions
- ▶ Dynamic analysis
- ▶ Prediction of thermodynamic potential
- ▶ Prototype construction
- ▶ Mechanics development
- ▶ Function development
- ▶ Engine calibration